



Oval Wheel Flowmeter

for low and high viscous liquids



measuring
•
monitoring
•
analysing

DON



- Measuring range:
0.5 ... 36 l/h und 150 ... 2500 l/min
- Viscosity range: 0...1000 cP
(higher on request)
- Accuracy: $\pm 0,2\%$... 1% of reading
- Material: aluminium or stainless steel
- p_{\max} : 100 bar; t_{\max} : 150 °C
- Pulse output, LCD display, 4...20 mA,
alarms, mechanical register



S4

KOBOLD companies worldwide:

ARGENTINA, AUSTRALIA, AUSTRIA, BELGIUM, BULGARIA, CANADA, CHILE, CHINA, COLOMBIA, CZECHIA, EGYPT, FRANCE, GERMANY, GREAT BRITAIN, HUNGARY, INDIA, INDONESIA, ITALY, MALAYSIA, MEXICO, NETHERLANDS, PERU, POLAND, REPUBLIC OF KOREA, ROMANIA, SINGAPORE, SPAIN, SWITZERLAND, TAIWAN, THAILAND, TUNISIA, TURKEY, USA, VIETNAM

KOBOLD Messring GmbH
Nordring 22-24
D-65719 Hofheim/Ts.
Head Office:
+49(0)6192 299-0
+49(0)6192 23398
info.de@kobold.com
www.kobold.com

Principle of Operation

Oval gear flowmeters are categorised as positive displacement flow technology. When liquid flows through this type of positive displacement flowmeter, two oval geared rotors measure a constant volume per rotation within a precisely machined measuring chamber. With each rotation, a constant volume of liquid is measured. The rotation of the oval gears is sensed via magnets embedded within the rotors. These magnets transmit a high resolution pulse output. The output signal can be process externally via a remote display controller or PLC or via a variety of output/display options available as accessories attached to the flowmeters.

Operation:

Liquid travels around the crescent shaped chambers created by the rotational movement of the rotors

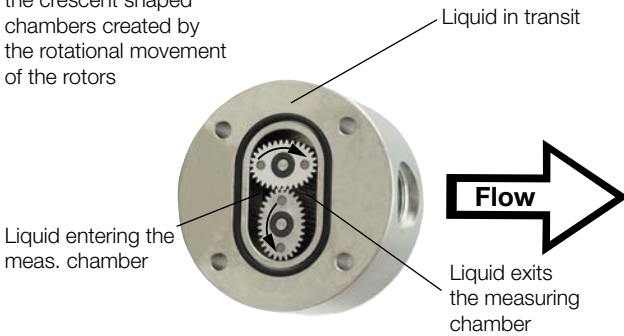

The positive displacement flow technology allows for precise flow measurement of most clean liquids regardless of the media conductivity. Other liquid properties also have a minimal effect on the performance of this type of meter. Flow profile conditioning is not required as with alternative flow technology options making oval gear installations simple to install in tight spaces and at an economical price.

Areas of Application

For all viscous, non abrasive clean liquids like:

- Petroleum ● Oil ● Chemicals
- Grease ● Fuels ● Ink etc.
- Pastes ● Water

Stainless steel flowmeters are suited to most water based products and chemicals and aluminium meters are suitable for fuels, fuel oils & lubricating liquids.

Technical Details

Material

DON-1	
Body:	aluminium
Oval wheels:	PPS GF30/PTFE
Axes:	stainless steel 1.4404
DON-2	
Body:	stainl. steel 1.4404 DON-x05...DON-x15 stainl. steel 1.4404/ 1.3955 DON-x20... DON-x60
Oval wheels:	stainl. steel 1.4404 DON-x05...DON-x40 stainl. steel 1.3955 DON-x45...DON-x60
Bearing:	carbon graphite
Axes:	stainless steel 1.4404
DON-8	
Body:	stainl. steel 1.4404 DON-x05... DON-x15

Oval wheels:	stainl. steel 1.4404/ 1.3955 DON-x20... DON-x60
Axes:	PPS GF30/PTFE stainless steel 1.4404
O-rings:	medium temperature FKM: -20...+150 °C NBR: -20...+100 °C FEP-O-seal: -15...+130 °C (FEP-O-seal, FEP encased, with solid core EPDM)
Cover for cable connection:	polyamide PA6 GF35 UL94 HB/VO stainless steel 1.4404 (optional)

Material Screws

For aluminium	
Housing:	stainless steel (standard) steel, coated with GEOMET® 321 (DON-A25)
For stainless steel	
Housing:	stainless steel (standard) steel, coated with GEOMET® 321 (optional) for higher pressure rating (see order details)

Accuracy (under reference conditions*):	
SS-rotors:	± 1 % of reading (DON-x05...DON-x15) ± 0.5 % of reading (DON-x20...DON-x60) ± 0.2 % of reading (DON-x20...DON-x60; with optional Z3/E3-electronics based on linearisation function)
PPS-rotors:	± 1 % of reading (DON-x20...DON-x60) ± 0.5 % of reading (DON-x20...DON-x60; with optional Z3/E3-electronics based on linearisation function) ± 1 % of reading (option M) (better accuracy for higher viscosities on request)

Additional max. inaccuracy for analogue outputs 4-20 mA:	+/-0,15% full scale
Repeatability:	typ. ± 0.03 %
Protection class:	IP 66/67 (IP 65 for M4)
Medium temp.:	-20 °C... +80 °C for options Lx, Zx, M4, DON-1/DON-8 and -20 °C... +120 °C for DON-2 with pulse output and options Zx with cooling fins (+150 °C with option T0) for models with PPS-rotors, max. temp. is limited to +80 °C
Ambient temp.:	-20 °C... +80 °C, option M4 0 °C... +60 °C M20 x 1.5, ½" NPT adapter
Cable entry:	
ATEX-approval (option E1/E3):	Ⓔ II 2G EEEx ia IIB T4 (-20 °C ≤ Ta ≤ +60 °C)
(option HE, DE, GE, LE, RE):	Ⓔ II 2G Ex d IIC T4...T6 Gb Ⓔ I M2 Ex d I Mb (st. steel models only)

* Reference conditions: x05...x20 (mineral oil 10 cSt, 20 °C, 5 bar);
x25...x60 (mineral oil 3 cSt, 20 °C, 1 bar)



Maximum Pressure (threaded version)

Model	Maximum pressure (bar)			
	DON-1	DON-2/8	DON-1.. (Option-M4)	DON-2/8 (Option-M4)
DON-x05	64	100	-	-
DON-x10			-	-
DON-x15		100	-	-
DON-x20		70*	40	40
DON-x25	60*			
DON-x30	40	50		
DON-x35			30	
DON-x40	16	16	16	16
DON-x45				
DON-x50				
DON-x55				
DON-x60				

with flanges, maximum pressure rating as above or as per flange rating, whichever is lower

* max. pressure rating of 100 bar possible with steel screws (see order details)

Recommended Filter

DON-x05 ... DON-x15 < 75 µm micron (200 mesh)

DON-x20 ... DON-x35 < 150 µm micron (100 mesh)

DON-x40 ... DON-x60 < 350 µm micron (45 mesh)

Pulse Output

Reed switch pulse output (...R0/RE)

The reed switch output is a two wire normally open SPST voltage free contact ideal for installations without power or for use in hazardous area locations when Intrinsically Safe (I.S.) philosophy is adopted.

Note: when using the reed switch output the liquid temperature must not change at a rate greater than 10°C per minute.

Average switching life of reed contact (MTTF):

max. Load (100 V/ 10 mA) 5×10^5 switching cycles

min. Load (<5 V/ 10 mA) 5×10^8 switching cycles

Power supply: max. 30 V_{DC}, max. 200 mA

Hall sensor pulse output (...H0/HE)

In the electronics options H0/HE, a Hall Effect sensor is combined with an active push-pull output. The electrical connection is provided in 3-wire version. The output is actively switched either to +Vs or to ground. The external supply voltage is 8 ... 30 V_{DC}. No additional external circuit is required (e.g pull up resistor). The high signal is approximately equal to the supply voltage +Vs and the low signal is approximately 0 V. The electrical load may optionally be connected to the supply voltage or to GND.

Maximum output current (current source or sink): 100 mA (short circuit protected).

Hall sensor pulse output (...B0/BE)

Like options H0/HE, however with bipolar sensors and alternating polarised magnets. This option is used for pulsating flows, but has halved K-factor as compared to H0/HE.

High-resolution Hall sensor pulse output, (...G0/GE)

Like options H0/HE; model DON-x05 and DON-x10 can be supplied with four times the count of pulses per liter (see table «Output Pulse Resolution» on the following pages).

Quadrature hall effect pulse output (...D0/DE)

DON instrument with option D0/DE is provided with two independent Hall sensors. The two hall effect sensors are arranged to give separate outputs out of phase with one another.

The QUAD output is mostly suitable for custody transfer with redundant signal or for detecting bidirectional flows (detection of flow direction).

Maximum output current per channel (current source or sink): 100 mA (short circuit protected).

Option L0/LE

The options L0 and LE (Ex) are available with loop powered 4-20 mA output. The loop is supplied with an external power supply 16...32 V_{DC}. The maximum resistance of the series loads (PLC analog input/display electronics) depends on the magnitude of the supply voltage and can be calculated as:

$$\text{Max. load [Ohm]} = (+Vs - 9 V_{DC}) / 0.02 \text{ A } [\Omega]$$

$$\text{Example: } +Vs = 32 V_{DC} = > \text{max. load} = 1150 \Omega$$

$$+Vs = 16 V_{DC} = > \text{max. load} = 350 \Omega$$

The load can be inserted at any point in the current loop observing correct polarity.

Mechanical totaliser (...M4)

The flowmeters type DON-x20... up to DON-x60... are available with a 4-digit resettable mechanical totaliser and indication of accumulated total value. The motion of the rotors is transmitted to the mechanical register totaliser via an interfacing reduction gear train and dynamic seal assembly.

Option M4 is available for volume units litre and gallon.

Body material: enamelled die-cast aluminium, powder-coated

Protection: IP65

Ambient temp.: 0 ... +60 °C

Medium temp.: -20 ... +80 °C



Electronic with LCD Display

Model	..Z1	..Z2	..Z3	..E1	..E3
Function	dual totaliser	Dosing unit	Rate/Counter	dual totaliser	Rate/Counter
Power supply					
Battery-powered (outputs inactive)	yes	no	yes	yes	yes
External (also for backlighting)	8 - 24 V _{DC}	12 - 24 V _{DC}	8 - 24 V _{DC}	8 - 24 V _{DC}	8 - 24 V _{DC}
LCD display					
Selectable units	yes	yes	yes	yes	yes
Decimal point	yes	yes	yes	yes	yes
Accumulative total	yes	yes	yes	yes	yes
Resettable total	yes	yes	yes	yes	yes
Linearisation	no	no	yes	no	yes
Rate display	yes	yes	yes	no	yes
Backlighting	yes	yes	yes	no	yes
Input					
Un-powered sensors	Reed switch				
Powered sensors	Hall sensor				
Outputs					
4-20 mA	no	no	yes	no	yes
Flow rate Alarm min./max.	no	no	NPN/PNP/PP	no	NPN/PNP/PP
Batch end & control	no	yes	no	no	no
Pulse outputs	no	no	PP	no	PP
2 x SPDT relays	no	yes	option	no	option
Installation					
IP 65	yes	yes	yes	yes	yes
Cable entries	M20x1,5/ ½" NPT	M20x1,5/ ½" NPT	M20x1,5/ ½" NPT	M20x1,5/ ½" NPT	M20x1,5/ ½" NPT
Medium temperature (Option: max. +120 °C)	-20...+80 °C	-20...+80 °C	-20...+80 °C	-20...+80 °C	-20...+80 °C
Ambient temperature	-20 ... +80 °C			0 ... +60 °C	
Housing material	PA6 GF35 UL94 HB/VO/PC UL94 V-2				
ATEX approval	no	no	no	yes	yes

*replaces solid state outputs



DON Pressure Drop Loss Curves vs Viscosity

x05/x10

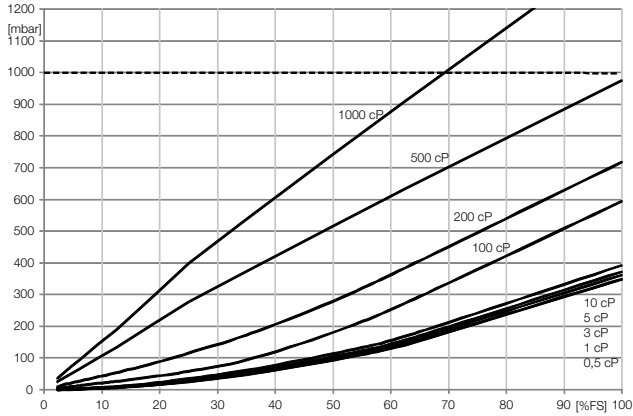

x15/x20

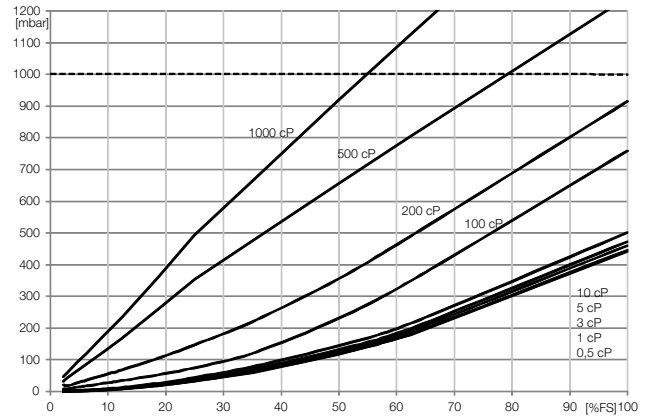

x25/x30/x35/x40

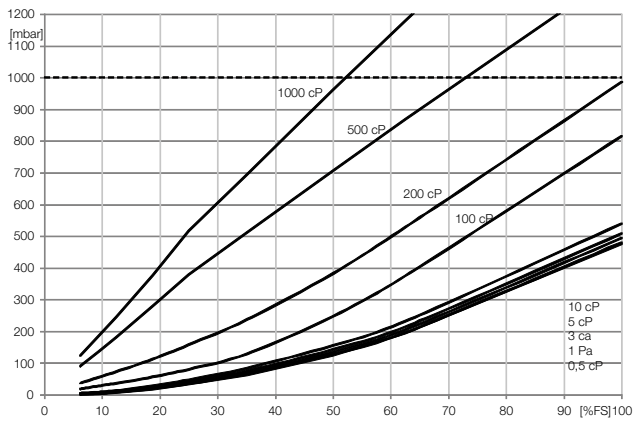

x45/x50/x55/x60

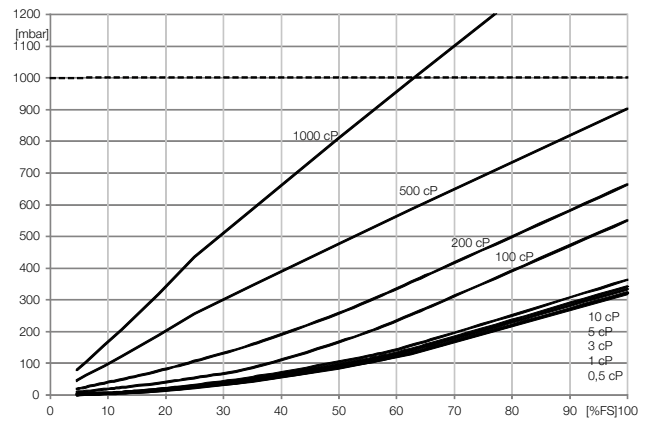

Pressure drop limit verses flowrate

The curves above represent the pressure drop for standard cut oval rotors. Special cut rotors option „S“ have alternate tooth relieve which effectively reduces the pressure drop by 50%. When sizing a meter, be sure your selection falls **below the 1 bar maximum allowable pressure drop line on the graph.**



Maximum Flowrate Multiplier (for higher viscosities)

Viscosities (cP)	Standard rotor	Special cut rotor
≤ 1000	1	1
≤ 2000	0.5	1
≤ 4000	0.42	0.84
≤ 6000	0.33	0.66
≤ 8000	0.25	0.5
≤ 30000	0.15	0.3
≤ 60000	0.12	0.25
≤ 150000	0.1	0.2
≤ 250000	0.05	0.1
≤ 1000000	0.025	0.05

Special cut rotors for higher viscosities

For viscosity > 1000 cP, special cut rotors option "S" should be used to reduce pressure drop. This applies to DON-x15 and larger sizes. For higher viscosities, the flowmeter max. flowrate is de-rated according to the attached chart.

Example: DON-x25 measuring oil at 8000 cP, max. flow 150 l/min x 0.5 = 75 l/min new maximum flow rate.

Output Pulse Resolution

Model	Measuring range [l/min]	Pulse/litre				
		Reed switch Rx	Hall sensor Hx	Hall sensor Bx	Quadr. hall sensor Dx	Hall sensor, high-resolution Gx
DON-x05	0.5 - 36 l/h	2670	2670	-	2670	11320
DON-x10	2 - 100 l/h	1054	1054	-	1054	4210
DON-x15	15 - 550 l/h	355	710	355	710	-
DON-x20	1 - 40	82	163	82	163	-
DON-x25	10 - 150	26	103	52	52	-
DON-x30	15 - 250	14	55	27	27	-
DON-x35	30 - 450	6.4	25.5	13.5	13.5	-
DON-x40	50 - 580	4.9	19.6	9.8	9.8	-
DON-x45	35 - 750	2.57	10.3	5.15	5.15	-
DON-x50	50 - 1000	1.5	5.9	3	3	-
DON-x55	75 - 1500	1.05	4.2	2.1	2.1	-
DON-x60	150 - 2500	0.56	2.3	1.15	1.15	-

The values in above mentioned table are only approximate guidelines. The actual value for pulse rate can deviate from the values in this table and is mentioned in calibration certificate delivered with the flowmeter.



Order Details (Example: DON-105H R1 1 L0 M 0)

Measuring range	Housing material ⁴⁾			Connection	O-Ring Material	Electronics	Cable entry	Option
	[l/min]	Aluminium with PPS Rotor	Stainless steel					
0.5-36 l/h	DON-105H	DON-205H	DON-805H	R1 = G 1/8 N1 = 1/8" NPT	1 = FKM 3 = FEP-O-ring 4 = NBR	R0 = Reed switch pulse output RE = Reed switch pulse output ATEX (Exd) H0 = Hall sensor (Push-Pull)/Reed switch, pulse output HE = H0 + ATEX B0³⁾ = for pulsating flow BE³⁾ = B0 + ATEX (Exd) T0⁸⁾ = Hall sensor (Push-Pull), +150°C, pulse output G0²⁾ = high resolution Hall sensor (Push-Pull) GE²⁾ = G0 + ATEX (Exd) D0 = Quad. Hall sensor 2 phased outputs (Push-Pull) DE = as D0 + ATEX (Exd) L0 = 4...20 mA loop powered analogue output LE = L0 + ATEX (Exd) Z1 = dual LCD totaliser Z2 = Dosing unit LCD Z3 = LCD totaliser, rate, outputs: 4-20 mA, alarm, pulse (ZOK-Z3) (impulses not for battery supply) Z6 = Z1 + B0 Z7 = Z3 + B0 Z8 = Z1 + D0 Z9 = Z3 + D0 E1 = Z1 + ATEX (Exi) E3 = Z3 + ATEX (Exi)	M = M20 N = 1/2" NPT S⁷⁾ = M20 with cooling fin T⁷⁾ = 1/2" NPT with cooling fin	0 = without K = check valve (from DON-x30) S³⁾ = special cut rotors for higher viscosities Y = special option (specify in clear text)
2-100 l/h	DON-110H	DON-210H	DON-810H	R2 = G 1/4 N2 = 1/4" NPT				
15-550 l/h	DON-115H	DON-215H	DON-815H	R3 = G 3/8 N3 = 3/8" NPT				
1-40	DON-120H	DON-220H	DON-820H	R4 = G 1/2 N4 = 1/2" NPT H4 ⁵⁾ = G 1/2 (100 bar) P4 ⁵⁾ = 1/2" NPT (100 bar)				
10-150	DON-125H	DON-225H	DON-825H	R6 = G 1 N6 = 1" NPT F6 = DIN flange, PN 16/40 (DN 25) A6 = ANSI flange, 150 lbs (1") B6 = ANSI flange, 300 lbs (1") H6 ⁵⁾ = G 1 (100 bar) P6 ⁵⁾ = 1" NPT (100 bar)				
15-250	DON-130H	DON-230H	DON-830H	R8 = G 1 1/2 N8 = 1 1/2" NPT F8 = DIN flange, PN 16/40 (DN 40) A8 = ANSI flange, 150 lbs (1 1/2") B8 = ANSI flange, 300 lbs (1 1/2")				
30-450	DON-135H	DON-235H	DON-835H	R9 = G 2 N9 = 2" NPT F9 = DIN flange, PN 16 (DN 50) C9 ⁹⁾ = DIN flange, PN 40 (DN 50)				
50-580	DON-140H	DON-240H	DON-840H	A9 = ANSI flange, 150 lbs (2") B9 ¹⁾ = ANSI flange, 300 lbs (2")				
35-750	DON-145H	DON-245H	DON-845H	RB = G 3 NB = 3" NPT FB = DIN flange, PN 16 (DN 80)				
50-1000	DON-150H	DON-250H	DON-850H	AB = ANSI flange, 150 lbs (3")				
75-1500	DON-155H	DON-255H	DON-855H	RC = G 4 NC = 4" NPT FC = DIN flange, PN 16 (DN 100)				
150-2500	DON-160H	DON-260H	DON-860H	AC = ANSI flange, 150 lbs (4")				

¹⁾ Only for DON-x35 ²⁾ Only for DON-x05 and DON-x10 ³⁾ Not for DON-x05 and DON-x10 ⁴⁾ Replace 'H' with 'G' to order GPH (GPM)
⁵⁾ With steel screws, only for DON-2... and DON-8... ⁶⁾ Only for DON-x20...DON-x60. Please specify the flow direction in clear text while ordering. Standard flow direction is from bottom to top ⁷⁾ Only for electronic options -Zx, not for DON-1... and DON-8... ⁸⁾ Only for DON-2...and DON-8...

Dimensions DON-1(2/8)...

DON-x05 DON-x15

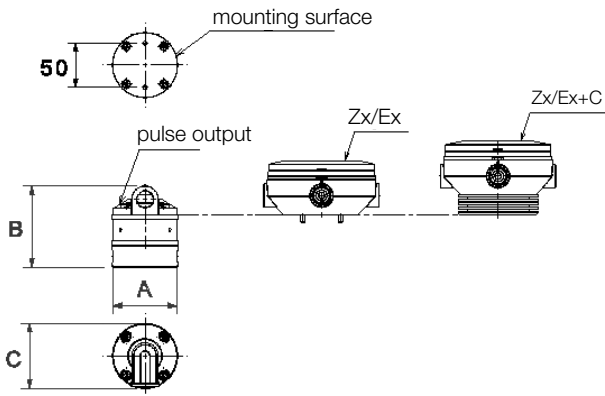

DON-x45 DON-x60

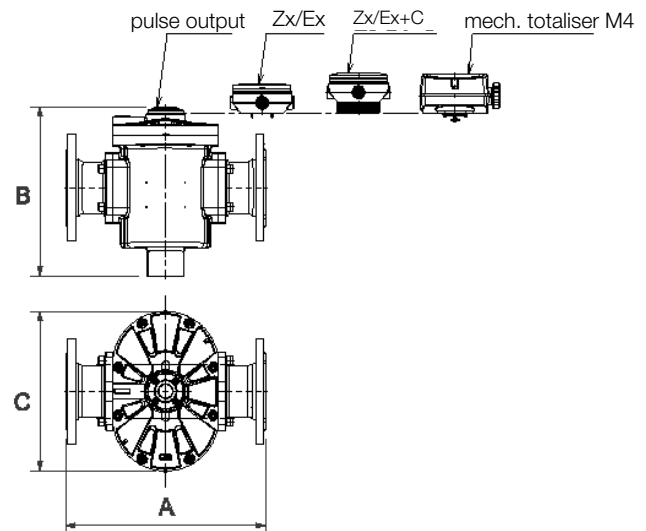

DON-x20 DON-x40

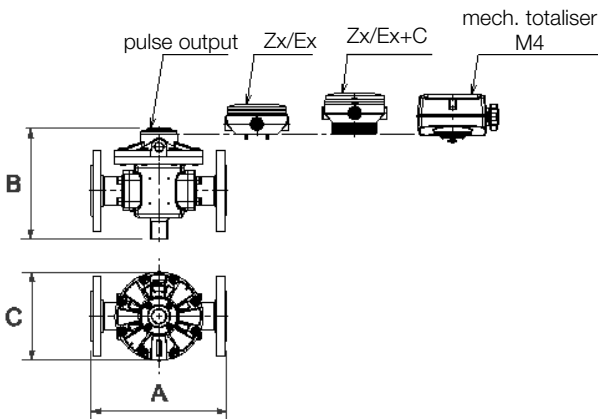

Electronic with LCD display / Zx/Ex

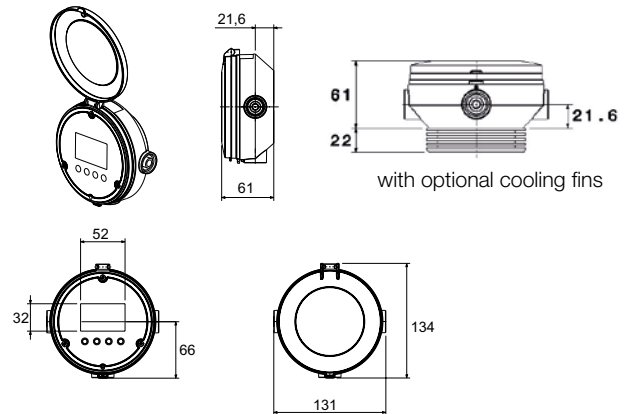

Dimensions DON-1(2/8).... (± 2 mm)

Model	A [mm]		B [mm]			C [mm]		
	Thread connection	Flange connection	Pulse output	Zx/Ex	Mechanical totaliser M4	Pulse output	Zx/Ex	Mechanical totaliser M4
DON-x05	68	-	92	131	-	72	134	-
DON-x10	68	-	92	131	-	72	134	-
DON-x15	68	-	99	138	-	72	134	-
DON-x20	110	-	105 (101)	134 (130)	182 (178)	112	134	165
DON-x25	176	237	136	165	194	120	134	170
DON-x30	188	252	166	195	223	163	163	200
DON-x35	212	277	172	201	244	180	180	200
DON-x40	212	277	246	275	299	180	180	200
DON-x45	266	354	232	261	284	238	238	239
DON-x50	294	382	229	258	302	290	290	290
DON-x55	294	388	274	303	347	290	290	290
DON-x60	320	414	351	380	424	331	331	331

Note: Dimensions for DON-2/8... are specified in () only when they are different from DON-1...