



Maritime Industry

SHIPS CAN CONTINUE SAILING INTO EMISSION CONTROL AREAS
– RIGHT INTO THE FUTURE.

SICK
Sensor Intelligence.



TABLE OF CONTENTS MARITIME INDUSTRY





Tasks

Tasks in Maritime Industry 4

Applications in focus

Fuel supply 8

Monitoring the efficiency and separation efficiency
of the DeNO_x system 10

Wet flue gas desulfurization system 12

Continuous emission monitoring system 14

Loading and unloading Ships 16

Products

Product overview 19

General information

Company 28

Industries 30

SICK LifeTime Services 32

Versatile product range for industrial automation 34

Industrial communication and unit integration 38

Services 43

TASKS IN THE MARITIME INDUSTRY

The International Maritime Organization (IMO) has established regulations for the reduction of ship emissions. SICK analyzers successfully monitor flue gas scrubbers which remove, for example, SO_2 from marine diesel engine exhaust gases. SICK analyzer systems also measure other components such as CO , CO_2 , H_2O , NH_3 , O_2 and CH_4 in exhaust gas from turbines and boilers before and after catalysts or gas scrubbers. SICK also offers solutions to measure the volume flow of gases, such as exhaust gases, and natural gas as a fuel. This may be during cargo loading and unloading, as well as to determine the amount of fuel injected into an engine. When loading bulk materials, SICK sensors also monitor loading quantities, and prevent collisions between cranes.



Emission Monitoring

The regulatory requirements for emission monitoring are becoming more stringent worldwide. SICK analyzers and system solutions monitor and check emission limit values, contaminant emissions and the release of other substances into the environment.



Flue gas treatment

Scrubbers, catalytic reactors and particulate filters all remove gaseous pollutants from the flue gas. Gas analyzers provide real-time measurement to optimize removal efficiency. This optimization leads to significant savings of operating costs and less maintenance for ship operators.



Measuring

Monitoring material flow on, from and to the ship optimizes throughput, reduces loading time and saves maintenance time. SICK has a wide variety of sensors and sensor systems for precise and direct measurement of volume and mass flow.

Service

Competent consulting, qualified planning support, detailed project planning and engineering, installation and start-up – SICK provides all of these services by its own personnel. SICK also provides service support for equipment.

APPLICATIONS IN FOCUS MARITIME INDUSTRY





Applications in focus

① Fuel supply	8
② Monitoring the efficiency and separation efficiency of the DeNO _x system	10
③ Wet flue gas desulfurization system	12
④ Continuous emission monitoring system	14
⑤ Loading and unloading Ships	16

① Steam flow measurement for crude oil and heavy oil

Crude oil and heavy oil must be heated, using, for example, hot steam, before it can be pumped. This steam is either generated by the ship's boiler, or provided by service providers in the port when loading or unloading cargo. In order to ensure that sufficient steam is fed in and distributed, precise measurements are required in Ex areas. Moreover, the ability to measure steam flow accurately is relevant for determining the amount of steam supplied.

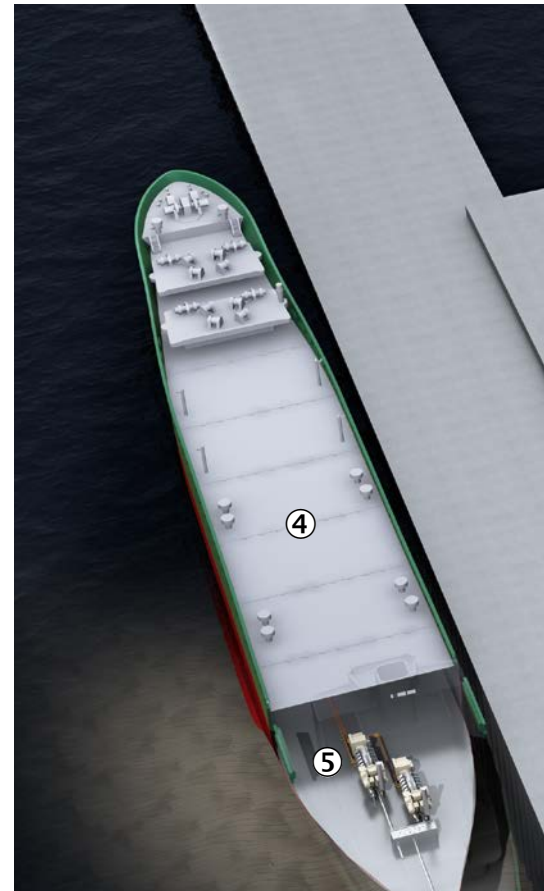

② Refueling ships with natural gas

Recording the volume of natural gas used in refueling the ship provides the information required to settle with the gas provider. The measurement accuracy and reliability of the measurement system are of vital importance in this respect. The ultrasonic gas flow measuring device FLOWSIC600 Quatro combines two high-precision gas flow meters with four measurement paths in one housing.

The FLOWSIC600 Quatro recognizes faults before they have a chance to affect the results of the measurement. The ultrasonic gas flow measuring device has a compact, rugged housing and works without issues, requiring no maintenance.

③ Flare gas measurement

Flare stacks primarily serve to burn combustible exhaust gas, which may escape through pressure relief valves during unplanned system operations. Gas flares are also used to burn gases for short periods during the commissioning and decommissioning of systems or system parts. The FLOWSIC100 Flare measures the gas flow in order to control the optimum mixture ratio of O₂, steam and flare gas in the flare.

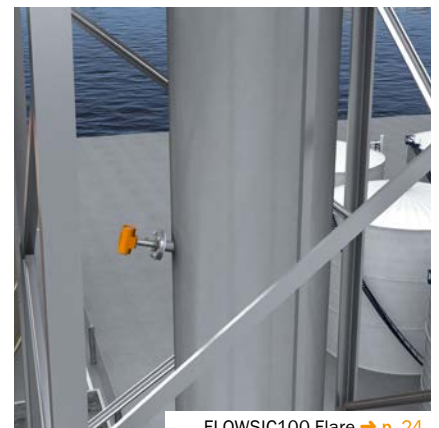



④ Measuring gas consumption in engines

Measuring the consumption of natural gas at the engine inlet provides the information required to properly inject gas into the engines, calculate the efficiency of the individual engines and to optimize gas consumption. The measurement accuracy and reliability of the measurement system are of vital importance in this respect. The new ultrasonic gas flow measuring device, FLOWSIC500, from SICK facilitates the high-precision measurement of natural gas distribu-

tion to the individual engine cylinders. The FLOWSIC500 does not feature any mechanically operated parts, and is therefore particularly reliable and requires little maintenance; significantly reducing operating costs.

⑤ Measuring the admission of liquid fuel to engines

Each kWh of engine drive power requires around 200 g of diesel. This equates to around three tons of fuel per hour for an engine with 15 MW drive power. The ATM60 absolute encoder can precisely detect the aperture angle of the engine's inlet valve for fuel. The payback for this investment is just a few days.

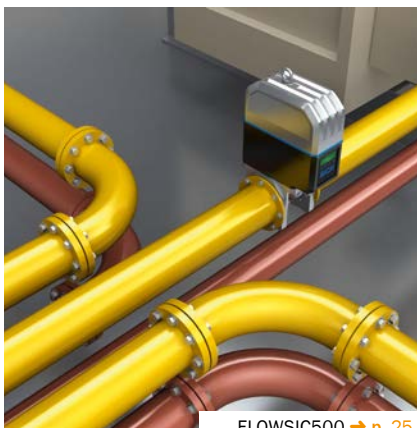

FLOWSIC500 → p. 25

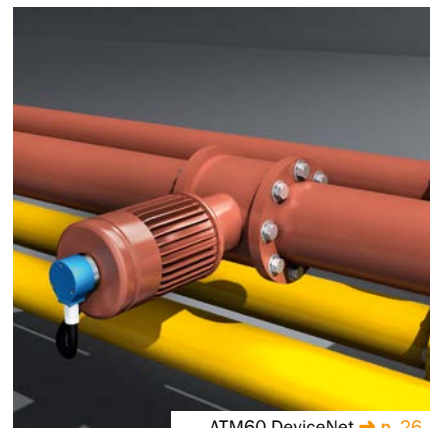

ATM60 DeviceNet → p. 26

① Recirculation air in the turbocharger

In order to ensure that less NO_x is formed in an engine, the oxygen content in the compressed airflow of the turbocharger has to be measured and controlled. The TDLS laser oxygen transmitter TRANSIC100LP facilitates real-time measurements, providing direct feedback for controlling the volume of fresh air. The analyzer is easy to install and operate. Test gas or flushing with nitrogen is not required, which reduces operating costs to a minimum. The heated optics prevent the formation of condensation, and the integrated drift monitor enables the TDLS laser oxygen transmitter to obtain stable measured values.



TRANSIC100LP → p. 20

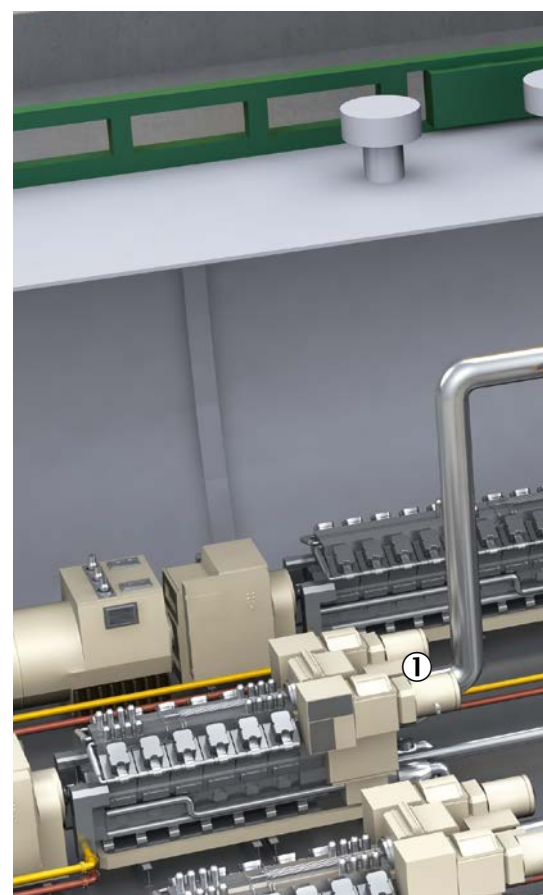

② Gas analysis prior to selective catalytic denitrification for process optimization

Selective catalytic reduction (SCR) is used to reduce NO_x. This adds a reagent such as ammonia (NH₃), which uses a catalyst to turn nitrogen oxide into water and nitrogen at around 400 °C. The concentrations of nitrogen oxide are measured at the inlet, and are included in the calculation of cleaning performance.

The concentration of H₂O and O₂ is measured for standardization purposes. The analyzer solution, MARSIC, is used here.



MCS100E HW → p. 22
MARSIC → p. 22

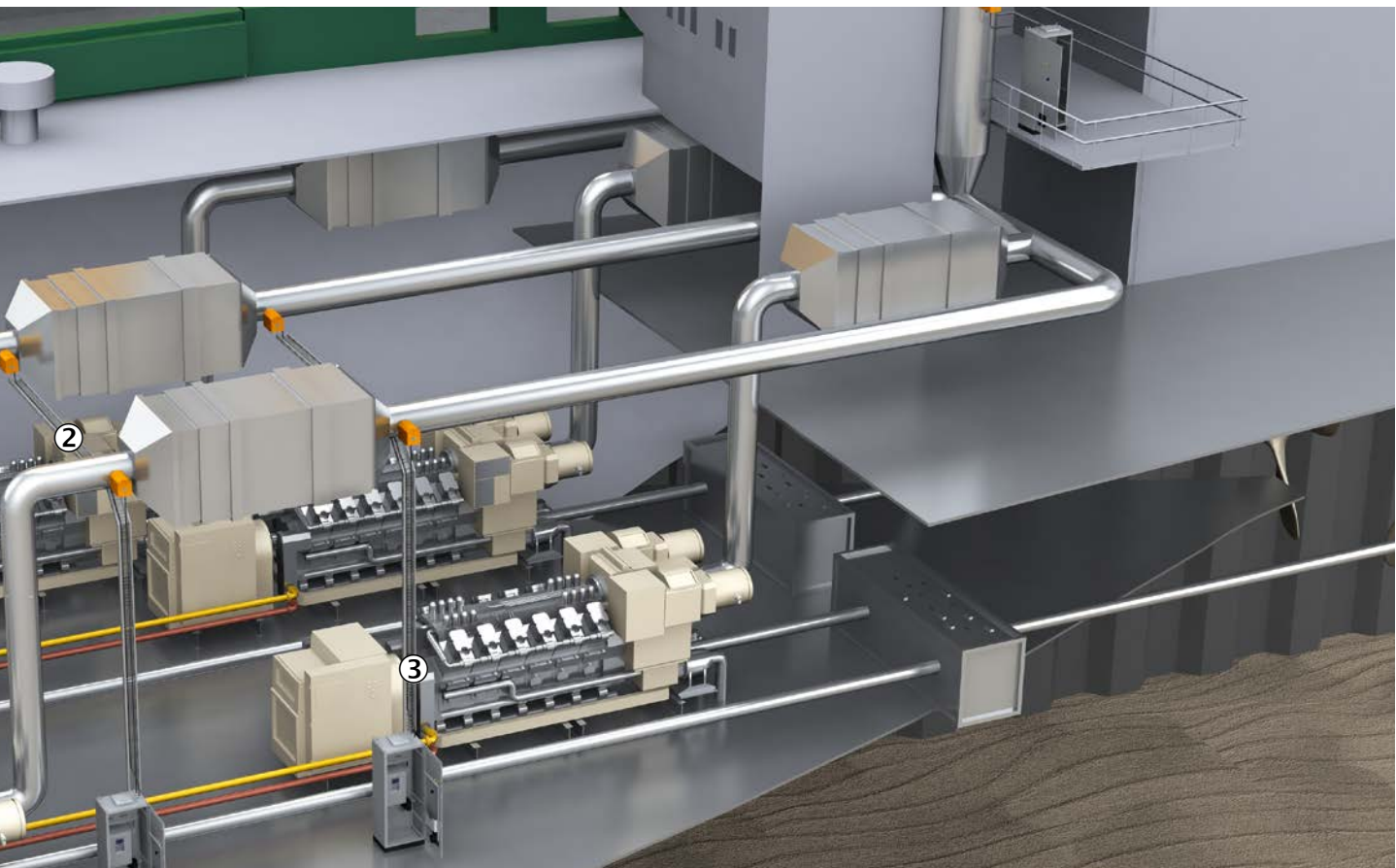

③ Gas analysis at the catalyst outlet preceding the heat exchanger

Environmental protection regulations stipulate that the concentration of NO_x must be reduced before it is released into the atmosphere. NO_x and NH₃ are measured at the catalyst outlet: The concentration of NH₃ (ammonia slip) is important to the control of NH₃ injection. Excess ammonia reacts with sulfur compounds, forming salts which may block components in the downstream area of the selective catalytic reduction process.

The NO_x value determines the efficiency. The analyzer solution, MARSIC, is particularly suitable for this measuring task, as it has been specifically designed for the exhaust gases from marine engines.



MCS100E HW → p. 22
MARSIC → p. 22



① Gas analysis at the inlet of the wet flue gas desulfurization system

The precise measurement of SO_2 , CO_2 and water in extremely humid conditions in the flue gas makes it possible to regulate the gas scrubber accurately. The performance data pertaining to the flue gas cleaning process is verified using a reliable, tested measuring technique. The results of the data enable the development and use of smaller flue gas scrubbers. This enables new projects to be carried out more accurately, as well as more cost effectively.

This is very economical and good for the environment, as CO_2 emissions decrease.



MCS100E HW → p. 22

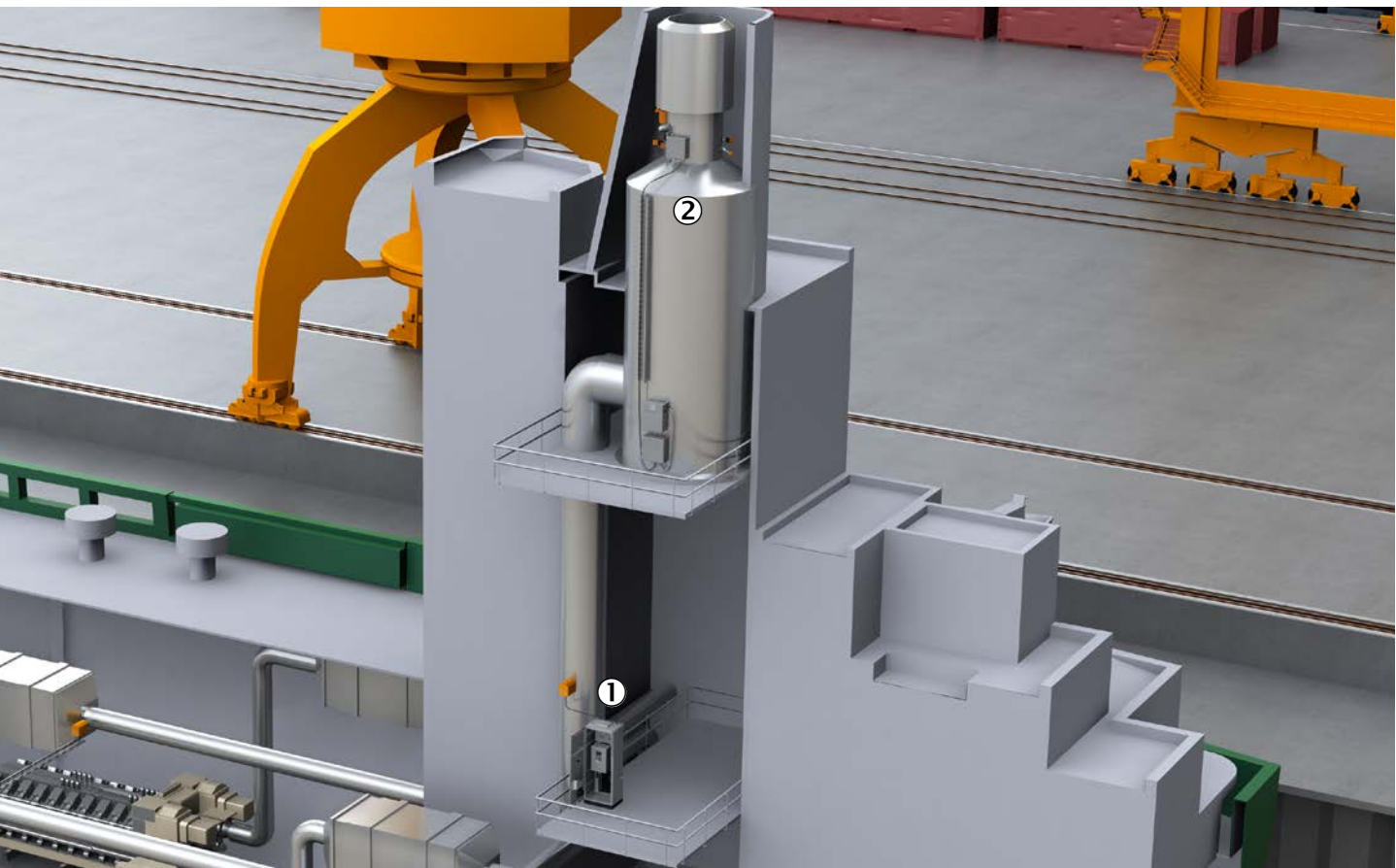

② Gas analysis at the outlet of the wet flue gas desulfurization system

The reliable, extractive, multi-component analyzer system is able to analyze additional relevant gas components in exhaust gas, depending on the engine. In sea areas where nitrogen oxide has to be measured (NECAs), nitrogen oxide is analyzed along with SO₂ and CO₂ simultaneously. The efficiency of the engine can be monitored online in order to optimize engines when changing fuel (e.g., from heavy oil to diesel).

Shorter changeover phases, such as when arriving in sea areas where emissions have to be monitored (ECAs), result in reduced changeover times, avoid engine damage, and save fuel.



MCS100E HW → p. 22
MARSIC → p. 22

① Monitoring of gas emissions on ships

Environmental regulations stipulate that certain harmful substances and reference values must be continuously observed. Regulations on emission monitoring vary from country to country. Measurement technology must be assessed with regards to its suitability in many countries – in accordance with the requirements of EN15267-3 in Europe, for example, or the EPA standards in the USA. SICK's wide range of products in the emission monitoring field ensures that it offers complete solutions. The analyzer solution MARSIC, developed specifically for ships, facilitates the measurement of NO, NO₂, SO₂, CO₂, H₂O, CO, CH₄, and O₂.



② Monitoring of dust emissions on ships

The International Maritime Organization (IMO) does not require dust and soot emissions on ships to be measured. Ships traveling through Arctic waters, however, must monitor the soot that they emit. The emission of soot leaves a black layer of soot on the white ice, making the ice melt more quickly when the sun shines. Monitoring soot emissions can serve to control and optimize the engine, particularly when changing to various fuels. This saves fuel and prevents engine damage.



③ Recording of mass emissions on ships

Continuous flow measurement in accordance with the technical standard NTC 2008 determines the mass flow of nitrogen oxides in gNO_x/kWh. This can be measured easily and directly using the FLOWSIC100 from SICK. This non-contact flow measurement is accurate to less than one percent of the measured value in temperature ranges from -40°C to 450°C.

The waste gas volume flow is recorded accurately, independent of the fuel and operation of the engines, boilers and gas scrubbers on board. Direct and reliable measurements facilitate the optimum operation of engines, boilers, and gas scrubbers.



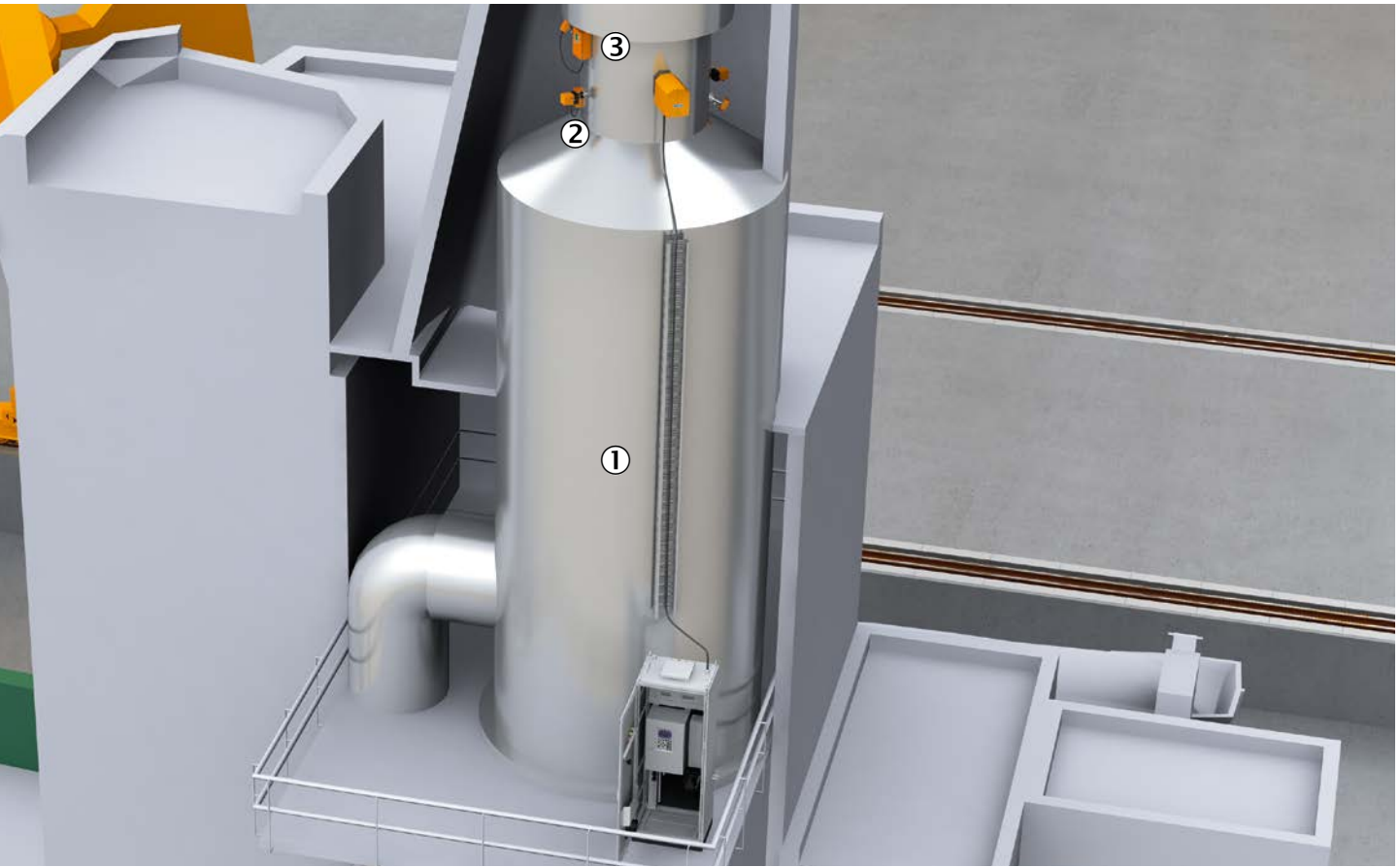

Recording and analysis of emissions data for ships

A data acquisition system, such as the MEAC, is ideal for recording, saving, analyzing, displaying, and exporting continuous emission data. This system has been approved by the classification society DNV GL as a touch panel PC in the 'at sea variant,' which has been specifically designed for ships. Reports are tailored to Annex IV of the MARPOL Convention.

The MEAC provides data evaluation that takes into account emission and ship data, such as current position and performance. The emission reports can be downloaded in a readable file format. Established data transmission protocols – Modbus and OPC – are available to digitally record ship data. Emission devices with measuring point switching can also be connected.



MEAC → p. 23

① Volume measurement for the loading and unloading of ships

Efficient loading processes on belts, stockpiles, ship loaders and silos require the precise measurement of the material flow in order to keep downtime to a minimum, and maximize control. It is very important to minimize loading problems when controlling the material flow to the port of loading. In the form of the Bulkscan® LMS511, SICK provides a comprehensive solution for these requirements, which is especially suitable if conventional scales or load cells are exposed to mechanical wear.

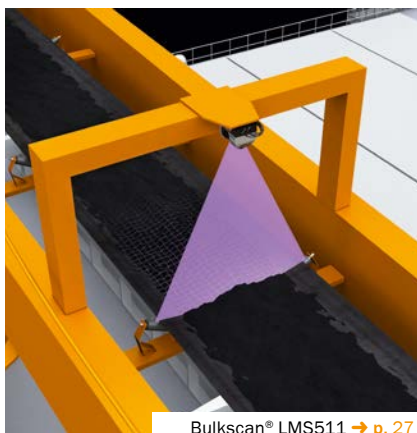

Bulkscan® LMS511 → p. 27



② Protection of ship loaders

Numerous areas on ships and in ports have to be monitored for ships to be loaded and unloaded safely. For example, loading hatches, superstructures, booms, and mobile machinery constitute potential hazardous areas. SICK solutions minimize the risk of collision, and maximize productivity.



LD-MRS → p. 26
LMSxx → p. 27

③ Inerting of tanks and cargo holds on ships

When refueling and loading ships with fuel or chemicals, gases that should not be emitted may escape. To minimize risks to the environment and the danger of explosion, TRANSIC100LP measures the content of atmospheric oxygen. SICK's solution is based on a redundant oxygen measurement system with two transmitters. The TRANSIC100LP is positioned on land in front of the purge air unit, which takes in and diverts the air displaced from the tank or cargo

hold. If the level of atmospheric oxygen in the piping is too high, it is displaced by adding inert gas, which prevents the creation of an explosive atmosphere.



TRANSIC100LP → p. 20



PRODUCT OVERVIEW MARITIME INDUSTRY





Product overview

Gas transmitters

TRANSIC100LP 20

Transmittance dust measuring devices

DUSTHUNTER T50 20

DUSTHUNTER T100 21

DUSTHUNTER T200 21

CEMS solutions

MARSIC 22

MCS100E HW 22

MEAC 23

Volume flow measuring devices

FLAWSIC100 23

Mass flow measuring devices

FLAWSIC100 Flare 24

FLAWSIC100 Process 24

Gas flow meters

FLAWSIC500 25

FLAWSIC600 25

Absolute encoders

ATM60 DeviceNet. 26

3D laser scanners

LD-MRS 26

2D laser scanners

LMS5xx 27

Flow sensors

Bulkscan® LMS511 27



TRANSIC100LP – At a glance

- O₂ transmitter based on high-performance laser spectroscopy (TDLS)
- For use in potentially explosive atmospheres (FM, ATEX and IECEx approvals)
- Measurement directly in-situ or extractive using a sample gas cell (option)
- Designed for heavy-duty industrial applications
- Compact design and easy to operate
- Long-term stability
- No moving parts

Your benefits

- Measures in real-time directly in the process
- Easy installation and operation
- Self-diagnostics with maintenance display
- Low requirements for gas conditioning
- Low operating costs: no consumables and no purging gas consumption
- Rugged: reliable measurement even in contaminated gases

→ www.mysick.com/en/TRANSIC100LP

For more information, just enter the link or scan the QR code and get direct access to technical data, CAD design models, operating instructions, software, application examples and much more.

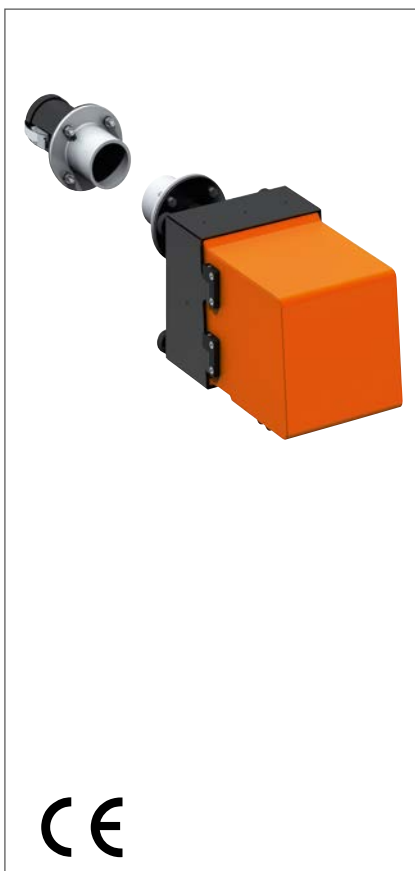

DUSTHUNTER T50 – At a glance

- For medium to high dust concentrations
- Automatic check of zero and reference point
- For small to medium measuring distances

Your benefits

- Easy installation, commissioning and operation
- Measurement independent of gas velocity, humidity and particle charge
- Low maintenance due to self-monitoring

→ www.mysick.com/en/DUSTHUNTER_T50

For more information, just enter the link or scan the QR code and get direct access to technical data, CAD design models, operating instructions, software, application examples and much more.





DUSTHUNTER T100 – At a glance

- For medium to high dust concentrations
- Integrated contamination check
- Automatic check of zero and reference point
- For small to large measuring distances

Your benefits

- Easy installation, commissioning and operation
- Measurement independent of gas velocity, humidity and particle charge
- Low maintenance due to self-monitoring
- Approved according to EN 15267

→ www.mysick.com/en/DUSTHUNTER_T100

For more information, just enter the link or scan the QR code and get direct access to technical data, CAD design models, operating instructions, software, application examples and much more.



DUSTHUNTER T200 – At a glance

- Integrated contamination check for sender/receiver and reflector unit
- Automatic self-alignment of the optical assembly
- Automatic check of zero and reference point
- For medium to high dust concentrations
- For small to large measuring distances

Your benefits

- Easy installation, commissioning and operation
- Measurement independent of gas velocity, humidity and particle charge
- Low maintenance due to self-monitoring and contamination check
- Approved according to EN 15267

→ www.mysick.com/en/DUSTHUNTER_T200

For more information, just enter the link or scan the QR code and get direct access to technical data, CAD design models, operating instructions, software, application examples and much more.





MARSIC – At a glance

- Rugged design and high level of measurement accuracy
- Up to four measurement points with one analyzer
- DNV GL type approval in accordance with MARPOL Annex VI, NOx Technical Code 2008 and MEPC.184 (59)
- Up to five measuring components at the same time: SO₂, CO₂, NO, NO₂ and O₂

Your benefits

- Low costs due to minimal maintenance requirements
- Several measurement points with just one analyzer
- High levels of availability and reliability
- Assemblies that are easy to replace during servicing
- Service support provided worldwide
- Quick access to expert support with remote maintenance
- Equipped for existing and future requirements thanks to its rugged design and high level of measurement accuracy

→ www.mysick.com/en/MARSIC

For more information, just enter the link or scan the QR code and get direct access to technical data, CAD design models, operating instructions, software, application examples and much more.



MCS100E HW – At a glance

- Extractive measurement of up to 8 IR-active gas compounds
- Additional oxygen and total hydrocarbon analyzers as an option
- Gas paths completely heated
- Test gas supply at the gas sampling probe or at the analyzer
- Back-purging of gas sampling probe for cleaning of filters
- Fast sample gas exchange for minimizing adsorption and desorption effects
- Automated sample point switching

Your benefits

- Measurement of several gas components with one analyzer
- Heated gas paths enables measurement of difficult gases like HCl and NH₃
- Long maintenance intervals (typically 6 months) due to self monitoring of the analyzer
- Selective measurement of NO and NO₂ – no converter required
- QAL3 drift test according to EN 14181 with internal calibration filter wheel – no test gas required

→ www.mysick.com/en/MCS100E_HW

For more information, just enter the link or scan the QR code and get direct access to technical data, CAD design models, operating instructions, software, application examples and much more.





MEAC – At a glance

- Evaluation according to EU directives 2000/76/EC and 2001/80/EC
- Evaluation according to 13., 17., 27. and 30. FICA and TA -Luft (Technical. Instructions on Air Quality Control)
- Inclusion of operational parameters and plant conditions
- Visualization of emission and operational data
- Remote data transfer, remote diagnosis and remote control
- Alarm signals when exceeding the limit values

Your benefits

- Software monitors all communications with connected field devices and control systems
- All values are stored on hard disk, thus it is possible to look at data history even after many years
- A routine back-up is made regularly on a second hard disk
- Screen displays and output of actual and historical data are freely configurable



→ www.mysick.com/en/MEAC

For more information, just enter the link or scan the QR code and get direct access to technical data, CAD design models, operating instructions, software, application examples and much more.



FLOWSIC100 – At a glance

- Rugged titanium transducers for high durability
- Corrosion-resistant material for application in aggressive gases (option)
- Integral measurement over the duct diameter with types H, M and S
- Probe type PR for economic installation from one side of the duct
- Automatic function control with zero and span point check

Your benefits

- Reliable flow measurement for ducts with small up to very large diameters
- High durability of the device
- Minimum operating and maintenance costs
- Accurate measuring results under difficult measuring conditions
- Measurement without pressure loss, therefore no influences on the process
- User-friendly operation via SOPAS ET software
- Reliable function monitoring due to enhanced diagnosis
- No purge air required for applications with gas temperatures up to 260 °C



→ www.mysick.com/en/FLOWSIC100

For more information, just enter the link or scan the QR code and get direct access to technical data, CAD design models, operating instructions, software, application examples and much more.





FLWSIC100 Flare – At a glance

- Highest measurement resolution and short response time
- Innovative sensor design for very high gas velocities
- Optimal signal transmission also at atmospheric pressure
- Remote installation of control unit up to 1,000 m away
- Single and multipath meter configuration
- Field repeatable check procedure of factory zero flow test
- Check cycle for automatic self-diagnosis / signal optimization

Your benefits

- Reliable process control by accurate measurement near to zero flow readings
- High measurement availability also under emergency plant operation conditions with high gas velocities up to 120 m/s
- Cost saving by remote installation of control unit in safe area
- System solution to serve three different flare measurements with a single control unit
- Cost saving by minimized installation using single probe version FLOW SIC100 EX-PR
- Securing optimal meter performance by continuous monitoring of meter function and extended field diagnostic capabilities

→ www.mysick.com/en/FLWSIC100_Flare

For more information, just enter the link or scan the QR code and get direct access to technical data, CAD design models, operating instructions, software, application examples and much more.



FLWSIC100 Process – At a glance

- Corrosion-resistant transducers made of stainless steel or titanium
- Process pressure up to 16 bar
- Explosion-proof version for applications in Zone 2 (ATEX) available
- Hermetically sealed ultrasonic transducers
- Measurement without pressure loss, therefore no influences on the process
- Automatic function control with zero and span point check

Your benefits

- Reliable and accurate measurement also at low gas velocities
- No movable parts, therefore low maintenance
- Measurement independent of pressure, temperature and gas composition
- No influence on the gas flow due to contact-free measurement
- Approved for usage in hazardous areas Zone 2 (ATEX)
- User-friendly operation and device diagnosis via MCU control unit and SOPAS ET operating software

→ www.mysick.com/en/FLWSIC100_Process

For more information, just enter the link or scan the QR code and get direct access to technical data, CAD design models, operating instructions, software, application examples and much more.





FLOWSIC500 – At a glance

- Cutting-edge technology: ultrasound
- Diagnostics and permanent operational check
- Durable and reliable without moving parts
- Replacable cartridge
- Straight inlet/outlet piping not required
- Overload-proof
- Optional integrated volume correction/data registration
- Battery or intrinsically safe power supply

Your benefits

- Ultimate measurement certainty and safety of continuous gas supply
- Reduction of installation costs due to integrated volume correction
- Simple installation, compatible with conventional technologies (turbine and rotary displacement meters)
- Minimal operating costs due to being nearly maintenance-free
- Easy recalibration due to straightforward cartridge replacement
- Reliable under dynamic load changes
- Self-sufficient operation

→ www.mysick.com/en/FLOWSIC500

For more information, just enter the link or scan the QR code and get direct access to technical data, CAD design models, operating instructions, software, application examples and much more.



FLOWSIC600 – At a glance

- High efficient ultrasonic transducers
- Direct path layout
- Intelligent self-diagnostics
- Compact, robust design
- Integrated log book and data logger
- Large measuring range 1:120
- Bidirectional measurement
- Low power consumption: <1 W

Your benefits

- Long-term stability, reliable measurement
- Low maintenance due to intelligent self-diagnostics
- Virtually immune to pressure regulator noise
- Ultrasonic transducers can be exchanged under operating pressure
- Wide application range

→ www.mysick.com/en/FLOWSIC600

For more information, just enter the link or scan the QR code and get direct access to technical data, CAD design models, operating instructions, software, application examples and much more.



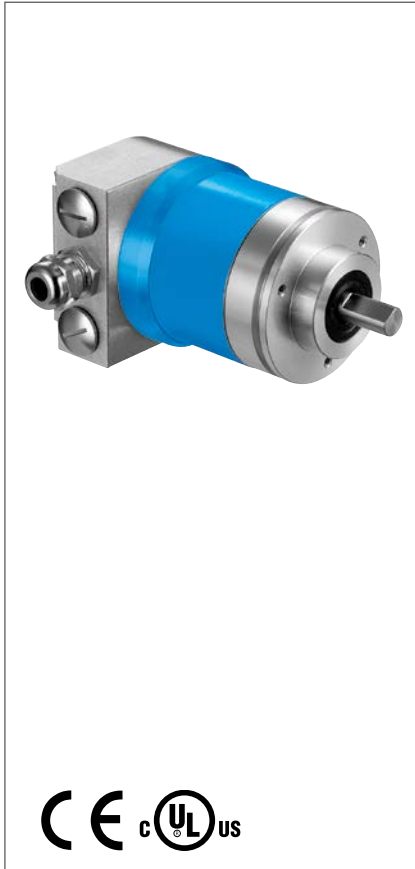

ATM60 DeviceNet – At a glance

- Extremely rugged, tried-and-tested absolute multiturn encoder with a resolution of up to 26 bits
- Mechanical interface: face mount, servo flange, blind hollow shaft and adapter accessories
- Zero set and preset functions via hardware/software
- No battery
- Electrical interface: CAN/DeviceNet specification 2.0B, electrically isolated; device profile: Generic [0]
- Electronically adjustable, configurable resolution
- Network status info via duo LED
- Magnetic scanning

Your benefits

- Fewer variants are required since one freely programmable encoder offers all singleturn and multiturn resolutions
- Easy setup due to electrical connection adapters (1 to 2x PG, 1 to 2x M12)
- Less maintenance and a long service life reduce overall costs
- Application flexibility due to easily interchangeable collets for the blind hollow shaft
- Quick commissioning using the zero set/preset function either at the press of the button on the device or via software
- Increased productivity due to highly reliable shock and vibration resistance
- Worldwide availability and service ensure quick and reliable customer service

→ www.mysick.com/en/ATM60_DeviceNet

For more information, just enter the link or scan the QR code and get direct access to technical data, CAD design models, operating instructions, software, application examples and much more.



LD-MRS – At a glance

- Simultaneous measurements on up to 8 scanning planes
- Weatherproof thanks to the multi-echo technology and IP 69K enclosure rating.
- Lightweight, compact design: Approx. 1 kg
- Wide temperature range: -40°C to $+70^{\circ}\text{C}$
- Low power consumption: 8 watts
- Supply voltage: 9 V DC to 27 V DC
- Different angular resolutions in the scanning range are available
- Integrated object tracking

Your benefits

- Simultaneous measurement on up to 8 planes compensates for vehicle pitch
- Easy sensor integration due to compact design
- Low operating costs due to low power consumption
- Fast data output, even when processing a high amount of information
- IP 69K-rated housing ensures accurate measurements in difficult environmental conditions
- Better detection by focusing on a defined scanning segment
- Data preprocessing allows tracking of up to 128 objects

→ www.mysick.com/en/LD-MRS

For more information, just enter the link or scan the QR code and get direct access to technical data, CAD design models, operating instructions, software, application examples and much more.





LMS5xx – At a glance

- Powerful and efficient laser measurement sensor for ranges of up to 80 m
- Outstanding performance in adverse environmental conditions due to multi-echo technology
- Up to IP 67 enclosure rating, built-in heater for outdoor versions, highly compact design
- Low power consumption
- Fast signal processing
- Multiple I/Os
- Synchronization of multiple sensors possible

Your benefits

- Superior performance in a vast range of applications
- Smallest sensor with highest accuracy in its class
- Comprehensive range of lines and models to suit all performance and price requirements
- Fast, reliable object detection in nearly any weather conditions
- Low power consumption reduces total cost of ownership
- Best price/performance ratio in this sensor class on the market
- Fast, easy commissioning due to SOPAS software
- Self-monitoring functions increase system availability

→ www.mysick.com/en/LMS5xx

For more information, just enter the link or scan the QR code and get direct access to technical data, CAD design models, operating instructions, software, application examples and much more.



Bulkscan® LMS511 – At a glance

- Non-contact measurement of volume and mass flow of bulk material
- Laser pulses with high angular resolution ensure outstanding image resolution
- 5-echo pulse evaluation produces highly reliable measurements
- Offers non-contact belt monitoring
- Integrated center-of-gravity calculator
- Robust structure for harsh ambient conditions
- Can also measure at low temperatures thanks to integrated heater
- Compact housing with IP67 enclosure rating

Your benefits

- Maximizes conveyor throughput
- Reduces maintenance costs by preventing belt slippage
- Increases the conveyor belt's service life
- Reduces loading time
- Increases efficiency by optimizing belt capacity
- Simple installation
- Low maintenance costs
- Offers savings through minimized energy consumption

→ www.mysick.com/en/Bulkscan_LMS511

For more information, just enter the link or scan the QR code and get direct access to technical data, CAD design models, operating instructions, software, application examples and much more.



WE DELIVER “SENSOR INTELLIGENCE.”

SICK sensor solutions for industrial automation are the result of exceptional dedication and experience. From development all the way to service: The people at SICK are committed to investing all their expertise in providing with the very best sensors and system solutions possible.

A company with a culture of success

Over 6,500 people are on staff, with products and services available to help SICK sensor technology users increase their productivity and reduce their costs. Founded in 1946 and headquartered in Waldkirch, Germany, SICK is a global sensor specialist with more than 50 subsidiaries and representations worldwide.

Our exemplary corporate culture fosters an optimum work-life balance, thus attracting the best employees from all over the world. SICK is one of the best employers – we have been among the winners of the prestigious German “Great Place to Work” award for many years in succession.



Innovation for the leading edge

SICK sensor systems simplify and optimize processes and allow for sustainable production. SICK operates at many research and development centers all over the world. Co-designed with customers and universities, our innovative sensor products and solutions are made to give a decisive edge. With an impressive track record of innovation, we take the key parameters of modern production to new levels: reliable process control, safety of people and environmental protection.



A corporate culture for sustainable excellence

SICK is backed by a holistic, homogeneous corporate culture. We are an independent company. And our sensor technology is open to all system environments. The power of innovation has made SICK one of the technology and market leaders – sensor technology that is successful in the long term.



“SENSOR INTELLIGENCE.” FOR ALL REQUIREMENTS

SICK is a renowned expert in many industries, and is entirely familiar with the critical challenges they face. While speed, accuracy and availability take center stage in all industries, technical implementations vary greatly. SICK puts its vast experience to use to provide with precisely the solution you need.

For applications worldwide

Hundreds of thousands of installations and applications go to prove that SICK knows the different industries and their processes inside out. This tradition of uncompromising expertise is ongoing: As we move into the future, we will continue

to design, implement and optimize customized solutions in our application centers in Europe, Asia and North America. You can count on SICK as a reliable supplier and development partner.



For your specific industry

With a track record of proven expertise in a great variety of industries, SICK has taken quality and productivity to new heights. The automotive, pharmaceutical, electronics and solar industries are just a few examples of sectors that benefit from our know-how. In addition to increasing speed and improving traceability in warehouses and distribution centers, SICK solutions provide accident protection for automated guided vehicles. SICK system solutions for analysis and flow measurement of gases and liquids enable environmental protection and sustainability in, for example, energy production, cement production or waste incineration plants.

For performance across the board

SICK provides the right technology to respond to the tasks involved in industrial automation: measuring, detecting, monitoring and controlling, protecting, networking and integrating, identifying, positioning. Our development and industry experts continually create groundbreaking innovations to solve these tasks.

→ www.sick.com/industries



SERVICES FOR MACHINES AND SYSTEMS: SICK LifeTime Services

SICK LifeTime Services is a comprehensive set of high-quality services provided to support the entire life cycle of products and applications from plant walk-through to upgrades. These services increase the safety of people, boost the productivity of machines and serve as the basis for our customers' sustainable business success. LifeTime Services range from product-independent consulting to traditional product services and are characterized by extensive industry expertise and more than 60 years of experience.





→ www.sick.com/service



Consulting & Design

- Plant walk-through
- Risk assessment
- Safety concept
- Safety software and hardware design
- Validation of functional safety
- CE-conformance check



Product & System Support

- Installation
- Commissioning
- Start-up support
- Calibration
- Helpline support
- 24 h helpline
- SICK Remote Service
- Troubleshooting on site
- Repair
- Exchange units
- Extended warranty



Verification & Optimization

- Inspection
- Stop time measurement
- Machine safety inspection
- Electrical equipment check
- Accident investigation
- Initial verification
- Maintenance
- Performance check



Upgrade & Retrofits

- Upgrade



Training & Education

- Training
- Seminars
- WebTraining

VERSATILE PRODUCT RANGE FOR INDUSTRIAL AUTOMATION

From the simple acquisition task to the key sensor technology in a complex production process: With every product from its broad portfolio, SICK offers a sensor solution that best combines cost effectiveness and safety.

[→ www.sick.com/products](http://www.sick.com/products)

Photoelectric sensors

- MultiTask photoelectric sensors
- Miniature photoelectric sensors
- Small photoelectric sensors
- Compact photoelectric sensors
- Cylindrical photoelectric sensors
- Fiber-optic sensors and fibers



Proximity sensors

- Inductive proximity sensors
- Capacitive proximity sensors
- Magnetic proximity sensors

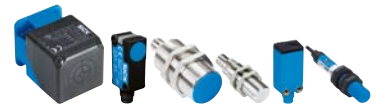

Magnetic cylinder sensors

- Analog positioning sensors
- Sensors for T-slot cylinders
- Sensors for C-slot cylinders
- Sensor adapters for other cylinder types



Registration sensors

- Contrast sensors
- Markless sensors
- Color sensors
- Luminescence sensors
- Fork sensors
- Array sensors
- Register sensors



Automation light grids

- Measuring automation light grids
- Switching automation light grids



Opto-electronic protective devices

- Safety laser scanners
- Safety light curtains
- Safety camera systems
- Multiple light beam safety devices
- Single-beam photoelectric safety switches
- Mirror columns and device columns



Safety switches

- Electro-mechanical safety switches
- Non-contact safety switches
- Safety command devices



sens:Control – safe control solutions

- Safety controllers
- Safe sensor cascade
- Safety relays



Gas analyzers

- Gas transmitters
- In-situ gas analyzers
- Extractive gas analyzers



Dust measuring devices

- Scattered light dust measuring devices
- Transmittance dust measuring devices
- Gravimetric dust measuring devices



Analyzer solutions

- CEMS solutions
- Process solutions



Traffic sensors

- Tunnel sensors
- Overheight detectors
- Visual range measuring devices



Ultrasonic gas flow measuring devices

- Volume flow measuring devices
- Mass flow measuring devices
- Flow velocity measuring devices
- Gas flow meters
- Flow computers



Motor feedback systems

- Motor feedback system rotary HIPERFACE®
- Motor feedback system rotary HIPERFACE DSL®
- Motor feedback system rotary incremental
- Motor feedback system rotary incremental with commutation
- Motor feedback system linear HIPERFACE®



Encoders

- Absolute encoders
- Incremental encoders
- Linear encoders
- Wire draw encoders
- Safety encoders



Identification solutions

- Bar code scanners
- Image-based code readers
- Hand-held scanners
- RFID



Vision

- Vision sensors
- Smart cameras
- High-end cameras



Distance sensors

- Short range distance sensors (displacement)
- Mid range distance sensors
- Long range distance sensors
- Linear measurement sensors
- Ultrasonic sensors
- Double sheet detection
- Optical data transmission
- Position finders



Detection and ranging solutions

- 2D laser scanners
- 3D laser scanners



Fluid sensors

- Level sensors
- Pressure sensors
- Flow sensors
- Temperature sensors



System solutions

- Customized analyzer systems
- Collision awareness systems
- Flexible automation systems
- Object detection systems
- Profiling systems
- Quality control systems
- Security systems
- Track and trace systems



EASY INTEGRATION INTO YOUR AUTOMATION WORLD

Sensor integration with SICK is easy and fast for you: Our intelligent sensor solutions and safety controllers provide different integration technologies which allow easy access – from HMI, PLC, and engineering tools – to data from our sensors. In this way, we support you towards solving your application rapidly and easily and increase machine reliability with a continuous diagnostic concept.

PLC and engineering tool integration

Function Blocks	
IO-Link devices Level sensors Pressure sensors Presence detection sensors Distance sensors	Bar code scanners, Image-based code readers 1D and 2D
Vision sensors Inspectors	RFID RFH6xx RFU62x, RFU63x
Absolute encoders AFS60 AFM60	Laser volume flowmeter Bulkscan® LMS511

Function blocks

The SICK function blocks quickly allow you to establish acyclic communication to our sensors within your PLC program. Additionally, complex and variable process data can be parsed into their individual information contents without programmer effort.

DTM (Device Type Manager)

FDT/DTM is a cross-manufacturer concept, with which configuration and diagnosis of devices from different manufacturers can be done with just one engineering tool.

TCI (Tool Calling Interface)

The Tool Calling Interface (TCI) makes it possible to call up a tool used to carry out parameterization and diagnosis of a field device via the existing communication infrastructure.

HMI integration

OPC server

OPC technology is used to exchange data between field devices and Windows-based applications. The SOPAS OPC server from SICK follows the OPC DA specification and thus can be used on Windows operating systems.



Web server

The SOPAS web server from SICK can be used everywhere, where a web browser is available. The web server is distinguished by its ability to both carry out pure data exchange and also to provide visualizations for the devices, which is a big advantage, particularly for vision sensors.

Fieldbus Communication Interface



Modbus®TCP

Our fieldbus and network solutions allow SICK sensors and safety controllers to be connected to all conventional automation systems. This guarantees an easy and fast access to the available data.

→ www.sick.com/industrial-communication

WWW.MYSICK.COM – SEARCH ONLINE AND ORDER

Search online quickly and safely – with the SICK “Finders”

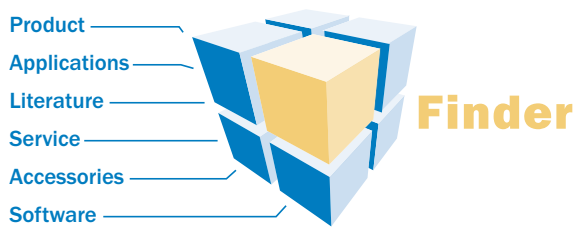

Product Finder: We can help you to quickly target the product that best matches your application.

Applications Finder: Select the application description on the basis of the challenge posed, industrial sector, or product group.

Literature Finder: Go directly to the operating instructions, technical information, and other literature on all aspects of products from SICK.

These and other “Finders” at → www.mysick.com

Efficiency – with the e-commerce tools from SICK

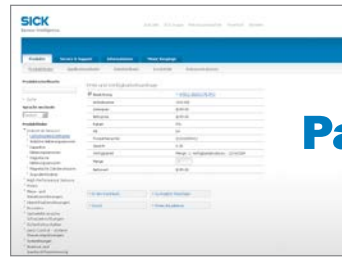

Partner Portal
www.mysick.com

Find out prices and availability: Determine the price and possible delivery date of your desired product simply and quickly at any time.

Request or view a quote: You can have a quote generated online here. Every quote is confirmed to you via e-mail.

Order online: You can go through the ordering process in just a few steps.

SERVICES FOR MACHINES AND SYSTEMS: SICK LifeTime Services

Our comprehensive and versatile LifeTime Services are the perfect addition to the comprehensive range of products from SICK. The services range from product-independent consulting to traditional product services.

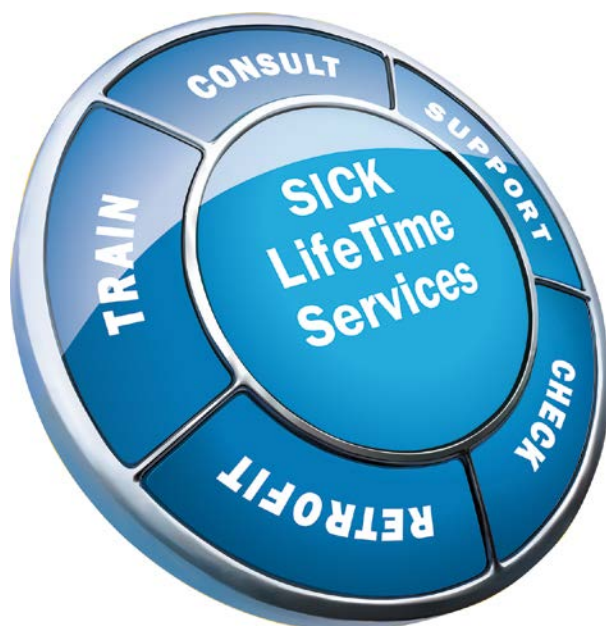

Consulting & Design
Safe and professional



Product & System Support
Reliable, fast and on-site



Verification & Optimization
Safe and regularly inspected



Upgrade & Retrofits
Easy, safe, economical



Training & Education
Practical, focused and professional

SICK AT A GLANCE

SICK is a leading manufacturer of intelligent sensors and sensor solutions for industrial applications. With more than 6,500 employees and over 50 subsidiaries and equity investments as well as numerous representative offices worldwide, we are always close to our customers. A unique range of products and services creates the perfect basis for controlling processes securely and efficiently, protecting individuals from accidents and preventing damage to the environment.

We have extensive experience in various industries and understand their processes and requirements. With intelligent sensors, we can deliver exactly what our customers need. In application centers in Europe, Asia and North America, system solutions are tested and optimized in accordance with customer specifications. All this makes us a reliable supplier and development partner.

Comprehensive services round out our offering: SICK LifeTime Services provide support throughout the machine life cycle and ensure safety and productivity.

For us, that is “Sensor Intelligence.”

Worldwide presence:

Australia, Austria, Belgium/Luxembourg, Brazil, Czech Republic, Canada, China, Denmark, Finland, France, Germany, Great Britain, Hungary, India, Israel, Italy, Japan, Mexico, Netherlands, Norway, Poland, Romania, Russia, Singapore, Slovenia, South Africa, South Korea, Spain, Sweden, Switzerland, Taiwan, Turkey, United Arab Emirates, USA

Detailed addresses and additional representatives → www.sick.com